

# **BOMAG**

**FAYAT GROUP**

## **MULTI PURPOSE COMPACTOR BMP 8500**

### **PERFORMANCE DATA**

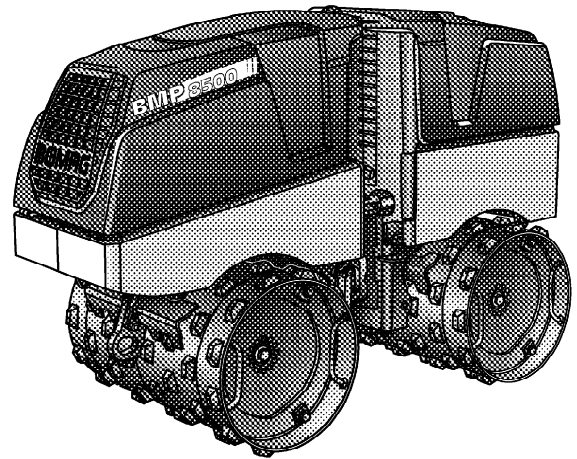

Machine type	Compaction output (m <sup>3</sup> /h) at recommended soil layer thicknesses		
	Gravel, sand	Mixed soil	Silt, clay
BMP 8500	52-82	52-82	30-40

# Technical Data

Shipping dimensions in m3

**BMP 8500**

2,056

## Standard

- ECOMODE
- Hydrostatic articulated steering, maintenance free
- Combination remote control cable/radio
- Dual directed-vibration system
- Two travel speed ranges
- 2 amplitudes
- Intelligent Vibration Control (IVC)
- Electric starter
- Hydrost. service brake
- Hydro-mechanical parking brake
- Back-up drive protection
- 2 scrapers per drum
- Battery disconnect switch
- Automatic shutdown at low oil level
- Automatic engine shut down at a lateral tipping angle of > 45°
- Full prot. hoods made of impact resistant compound material
- Single point lifting device
- Lockable engine cover and dash board
- Easy Service Concept
  - Diagnostic module with fault code display
  - Hour meter
  - foldable full protection hood

## Options

- Drum extensions (610/850mm)(+48kg)
- Environmentally compliant hydraulic oil
- Special painting
- Mobile quick charger
- Scrapers 850mm
- Service Kit

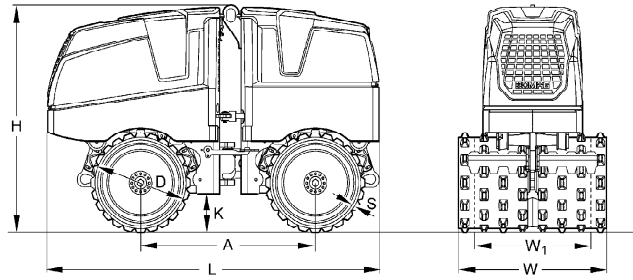

## Dimensions in mm

**BMP 8500**

A	D	H	K	L	S	W	W1
1000	520	1275	222	1897	25	850	610

## Technical Data

### Weights

Operating weight CECE .....	kg	1.595
Basic weight .....	kg	1.585
Average axle load CECE .....	kg	775

### Dimensions

Basic working width .....	mm	850
---------------------------	----	-----

### Driving Characteristics

Speed (1), forward .....	km/h	1,3
Speed (1), reverse .....	km/h	1,3
Speed (2), forward .....	km/h	2,5
Speed (2), reverse .....	km/h	2,5
Max. gradeability without/with vibr. ....	%	55/45

### Drive

Engine manufacturer .....	Kubota
Type .....	D 1005
Cooling .....	water
Number of cylinders .....	3
Performance ISO 9249 .....	kW 14,5
Speed .....	min-1 2.600
Fuel .....	diesel
Drive system .....	hydrost.
Driven drum .....	front + rear

### Brakes

Service brake .....	hydrost.
Parking brake .....	hydromec.

### Exciter system

Vibrating drum .....	front + rear
Drive system .....	hydraulic
Frequency .....	Hz 42
Amplitude .....	mm 1,12/0,56
Centrifugal force .....	kN 72/36

### Capacities

Fuel .....	l	24
------------	---	----

Technical modifications reserved. Machines may be shown with options.

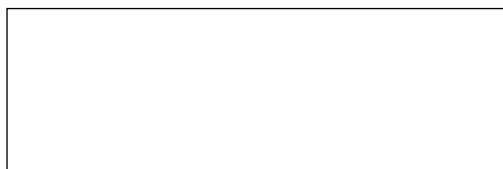

**BOMAG**  
 Hellerwald  
 D-56154 Boppard  
 P.O. Box 5162  
 Tel. (0)6742 - 1000  
 Fax (0)6742 - 3090  
 Fax (0)6742 - 3090

**BOMAG**  
**FAYAT GROUP**